

# VR-4100 Dimensions (Unit:mm)

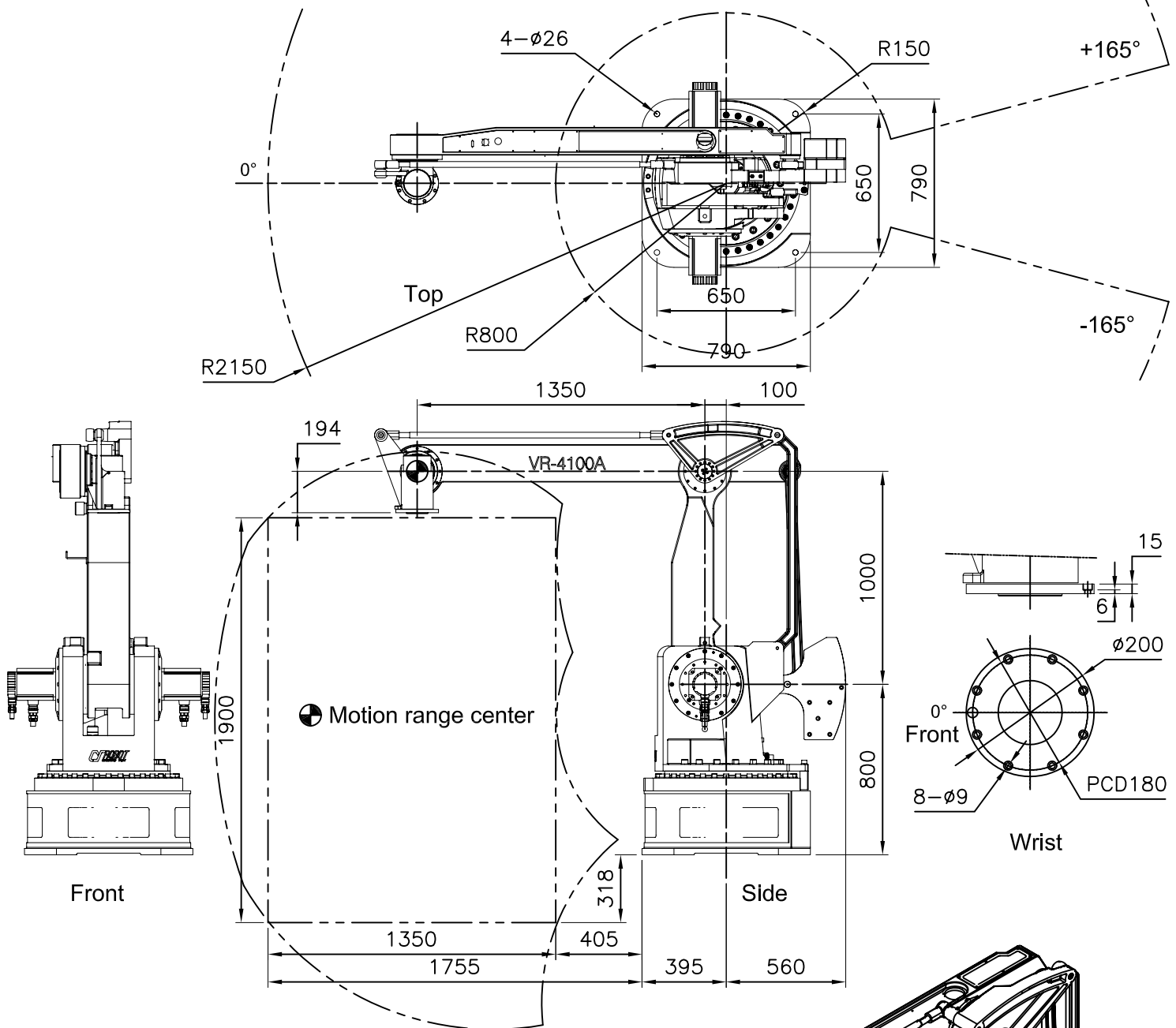

## VR-4100 Specifications:

Items	Specification	Remark
Type	Vertical Articulated Type	
Controlled axes	4 Axes(J1 · J2 · J3 · J4)	
Installation	Floor Mount	
Motion Range (Maximum Speed)	J1 330° = -165° ~ +165° (168°/sec)	
	J2 137° = -41° ~ +96° (126°/sec)	With brake
	J3 126° = -66° ~ +60° (168°/sec)	With brake
	J4 720° = -360° ~ +360° (202°/sec)	
Maximum load capacity at wrist	100Kg	Include finger
Drive method	AC Servo Motor	
Repeatability	±0.5mm	
Control method	Teach And Playback System	
Memory	2100 Points	
Inter Lock	Input=24 · Output=16	
Interface	RS-232C	
Installation environment	Temperature : 0~45°C	No condensation
	Humidity : 75%RH or less (Short Term 95%RH or less)	

